

SYSTEM 90

Installation Manual



Shipment Checklist Reminder	2
Installation Guidelines	3
Hardware	4
Tools	5
Electrical Information	6 - 7
• Electrical Hookup	6
• LED Wiring & Installation	6
• Trouble-shooting The LED System	7
Cabinet Installation	8 - 12
• Plot Plan Review	8
• Cabinet Installation	9 - 10
• Types Of Cabinet Corners	11 - 12
Flexible Fascia Installation	13 - 23
• Cold Weather Advisory	13
• Carrier Assembly	14 - 15
• Installing Fascia	16 - 20
• Installing Fascia Around Corners	21 - 22
• Trim, Tops, and Spring Cover Installation	23
Eggcrate Panel Installation	24
Care And Maintenance	25
Warranty Statement	26
Site Information Summary	Back Cover

REMINDER

Check off the entire contents of each shipping crate against the shipment packing list prior to removing any of the shipment contents from the original packaging.

All shipments must be inspected within two (2) working days after receipt. All items on this Bill Of Materials and/or Packing List have been shipped unless otherwise noted.

The receiver is responsible for contacting Sharpline Converting Inc. with any discrepancies in the shipment.

Freight damages and losses must be reconciled with the freight company at the receipt of the materials.



1444 S. Tyler Rd. • P.O. Box 9608
Wichita, KS 67209 • 67277-0608
(316) 722-9080 • (800) 888-4888
www.sharpline.com
siteinfo@sharpline.com
An ISO 9001 Certified Organization

112242-01

System 90™ Receiver's Clause Label

PAY ATTENTION TO ALL LABELS

Carefully read all labels for important information regarding the installation of System 90™ components.

SYSTEM 90™
BACKLIT FLEXIBLE FASCIA

SPRING PLACEMENT

12" to 36" Cabinet Height - Every 9"

37" to 60" Cabinet Height - Every 8"

See Installation Manual For More Details

999750

SHARPLINE ARCHITECTURAL
999750 200 PER BAG



2" X 1/2" TENSION SPRING WITH LOOP

999750

System 90™ Tension Springs Label provides information for spacing tension springs based on cabinet height.

**FLEXIBLE CONDUIT WHIP
routed between electrical
boxes must be secured
with nylon ties at each
rib to comply with
U.L. requirements.**



The Flexible Conduit Whip Label reminds installers that it must be secured with nylon ties at each rib to comply with U.L. requirements.

ATTENTION

**Z-CLIP HARDWARE
NOT PROVIDED!**

(SEE INSTALLATION MANUAL FOR DETAILS)

Look for 1" x 2 5/8"
product labels for
specific information on
the package contents.

System 90™ Flexible Backlit Fascia is designed for easy installation. An installation plot plan is furnished with the job packet that shows the location of all the cabinets to be used on the job site. Before beginning installation of the sign system, completely read this installation manual.

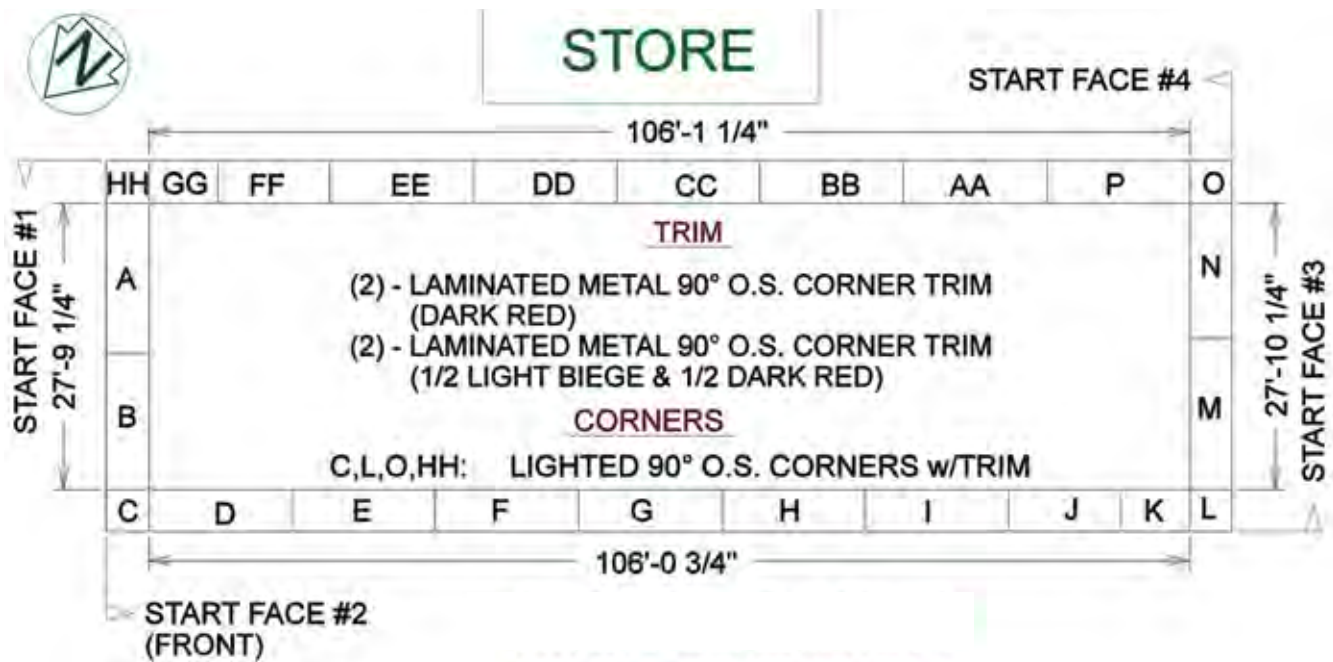

1. Review the cabinet layout on the provided installation plot plan to verify site dimensions for accuracy.
2. Schedule an electrician to be on site the day of installation. Review Electrical Information on pages 6-7.
3. Review, locate, and organize the necessary hardware detailed in the "Hardware List" on page 4.
4. Review and gather the necessary tools detailed in the "Tool List" on page 5.

System 90™ Installers will encounter various types of buildings and application surfaces when handling sign projects. With a wide variety of building structures and their corresponding sign installation conditions, professional sign installers need to use the proper tools and fastening practices to avoid costly mistakes.

Installers should always verify the wall composition before planning a project and selecting fasteners. Using the correct fasteners and installation techniques for a particular wall structure can keep a sign safe and secure for many years to come.

The International Sign Association provides a useful guide for wall-mounting signs:

<http://sharpline.com/images/pdf/ISA-sign-installation-guide.pdf>

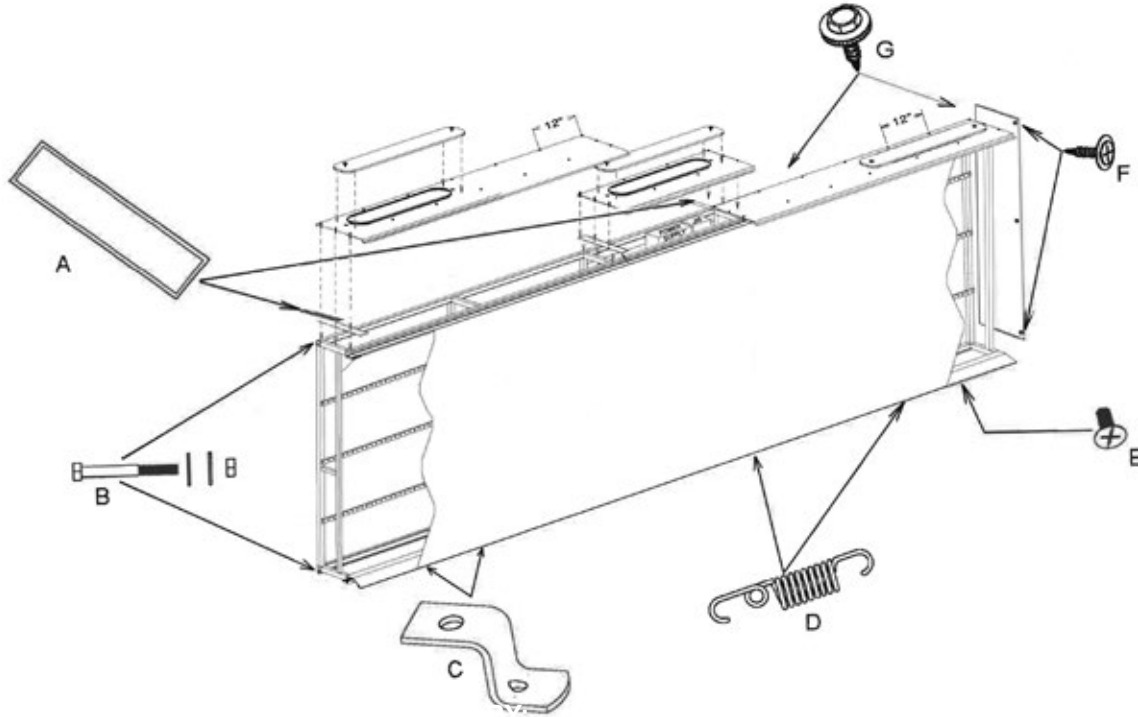

INCLUDED FACTORY HARDWARE

Items listed below are packaged and shipped with the order

A. Top Joint Plates *(with self adhesive tape)*

B. 5/16" x 2 1/2" Bolts / Washers / Nuts
(to assemble cabinets together)

C. "Z" Mounting Clips
(to secure sign cabinet to structure)

D. Tension Springs
(for attachment of flexible fascia)

E. 1/2" x 10-24 Flathead Phillips Screws
(for spring covers)

F. 1/2" Lathe Trim Screws
(for attachment of trim & end caps)

G. 3/4" x 10-16 TEK Screws
(to secure flexible fascia to vertical supports)

H. 1/4" x 72" Plated Steel Rods
(NOT PICTURED - for attachment of flexible fascia)

I. One Can of White Touch-up Paint
(NOT PICTURED - for scratches to sign cabinets)

J. Nylon Ties
(NOT PICTURED)

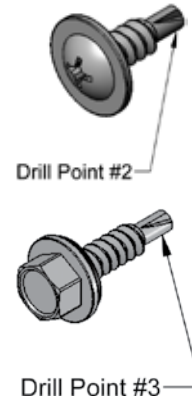

SUGGESTED HARDWARE NOT PROVIDED BY SHARPLINE

- **#14 X 1/4" Hex Head (Drill Point #3) Self-Drilling Screw** - Recommended to secure the "Z" clip to the structure when applicable. (Length of screw determined per application)
- **1/4" X 3/4" long Hex Washer Head (Drill point #2) Self-Drilling Screw** - Recommended to secure the "Z" clip to sign cabinet.

TOOLS PROVIDED BY SHARPLINE

- 1 pair - Horizontal Stretchers*
- 1 - Flexible Fascia Carrier*



**Stretchers and a flexible fascia carrier are provided with System 90™ shipments. Upon return of these tools to Sharpline, a credit of \$350 will be issued against the original invoice.*

Return tools in the original container provided to:

Sharpline Converting, Inc.
Attn: Graphic Structures Dept.
1444 S. Tyler Road
Wichita, KS 67209

Note: The 1" aluminum rod is disposable to make return shipment convenient.

REQUIRED TOOL LIST NOT PROVIDED BY SHARPLINE

- Bolt Cutters *(For cutting 1/4" steel rod)*
- Reciprocating Saw *(Two are required to install flexible fascia)*
- Scratch Awls *(Assembly of flexible fascia carrier)*
- 3/32" Allen Wrench *(With protective ends to secure flexible fascia)*
- Clamping Duck Bill Vise Grips *(Needed for trimming flexible fascia)*
- Utility Knife *(Used to tighten bolts holding cabinets together)*
- 1/2" Open End Wrench *(With 5/16" Nut Driver and Phillips bit)*
- 1/2" Socket & Ratchet *(Used to remove burrs on extrusions)*
- Drill *(Used to seal tops)*
- File
- Caulking Gun & Caulk
- Hammer
- Chalk Line
- Safety Rope
- WD-40
- TEK Screws or Rivets *(Small self-drilling)*
- Scissor Lift

ELECTRICAL HOOKUP

The System 90™ wiring is manufactured to comply with U.L. requirements. Check local codes before attempting any electrical hookup.

- Local codes may have different wiring requirements.
- It is the customer's responsibility to have modifications and on-site wiring completed by a licensed electrician.
- Turn off all power before installation, inspection, or removal of any electrical components.
- Properly ground the power supply enclosure.

LED WIRING & INSTALLATION

The Sharpline LED light bars are pre-installed at proper spacing and tested at the factory to verify that each LED light bar is working properly.

- The cabinets come with a conduit whip that is used to connect to the adjacent cabinet.
- Up to 7 cabinets can be connected on a 20 amp circuit (for a typical 3-row LED system).
- **DO NOT use the whips to bring power into the cabinets. Use whips only as secondary wiring.**
- Nylon ties are provided to secure the whips to the ribs to prevent shadows.
- Sharpline provided whips shall **NEVER** exit the sign system.

If Light Bar Is Detached From Mounting Clip

- Snap the light bar back into the mounting clip and inspect all low-voltage wires and connectors for damage. Repair any damaged wires.

Primary Power Connection

- Use a licensed electrician to connect primary power in accordance with NEC and local codes.
- Connect to the appropriate sized breaker or disconnect device for the supply line and neutral connections, in accordance with NEC and local regs.
- It is the sole responsibility of the electrical contractor to determine the proper location of entry and determination of the number of circuits required.

Primary Power Recommendation

- Use a maximum rating of 15 Amps on (1) 1P/20 Amp Breaker.
- Up to seven 15' - 0" modules (with 3-rows of LED) can be connected in a series using the factory provided 3/8" conduit whips.

NOTE: *Cutting off the wires will void the warranty. Please disconnect suspect bars by pressing on the connector tab and pulling apart.*

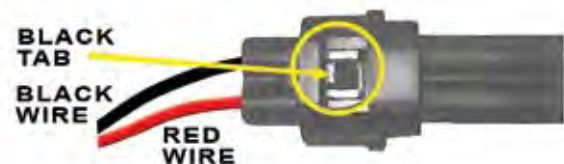

If any light bar(s) fail to illuminate, they should be returned to Sharpline Converting Inc.

TROUBLE-SHOOTING THE LED SYSTEM

Symptom: One or more rows of LED light bars do not light up.

Solution: Check connections at power supply to ensure **red-to-red** and **black-to-black** low voltage connections are secure. Check polarity connections between each light bar.

Symptom: The entire sign module does not light.

Solution: Check 120/277 VAC line input voltage and check power supply input/output connections.

Symptom: Several sequential sign modules do not light.

Solution: Check breaker and input voltage both at the breaker box and at the point that the primary circuit enters into the sign system. Check that each sign box is connected in the sequence using the factory-provided 3/8" conduit whips.

Symptom: LED modules are dim.

Solution: Verify that there are **not** any more than sixteen 3 ft. length LED light bars per 155W power supply.
Verify that there are **not** any more than eight 3 ft. length LED light bars per 90W power supply. Each low voltage circuit is rated at 3 amps output at 24 volts.

Symptom: Known overload occurred, and the sign module no longer lights.

Solution: Once excess load is removed, cycle the input power to restart the power supply.

LED LIGHT BAR CONNECTIONS

The wire colors must match **red-to-red** and **black-to-black**.



NOTE: Cutting off the wires will void the warranty. Please disconnect suspect bars by pressing on the black connector tab and pulling apart.

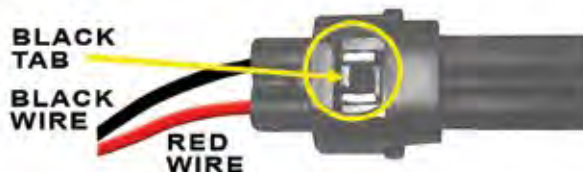

POWER SUPPLY & LED LIGHT BAR WARRANTY PROCEDURE

For power supply and LED light bar warranty information, contact an Architectural Sales Coordinator at 1-800-888-4888 Monday through Friday from 8:00 AM - 5:00 PM Central Time.

PLOT PLAN REVIEW

Refer to the plot plan for exact cabinet placement on the structure. Cabinet locations are labeled alphabetically on the plot plan and correspond directly to labels placed on the inside of each cabinet.

SYSTEM 90™ PLOT PLAN

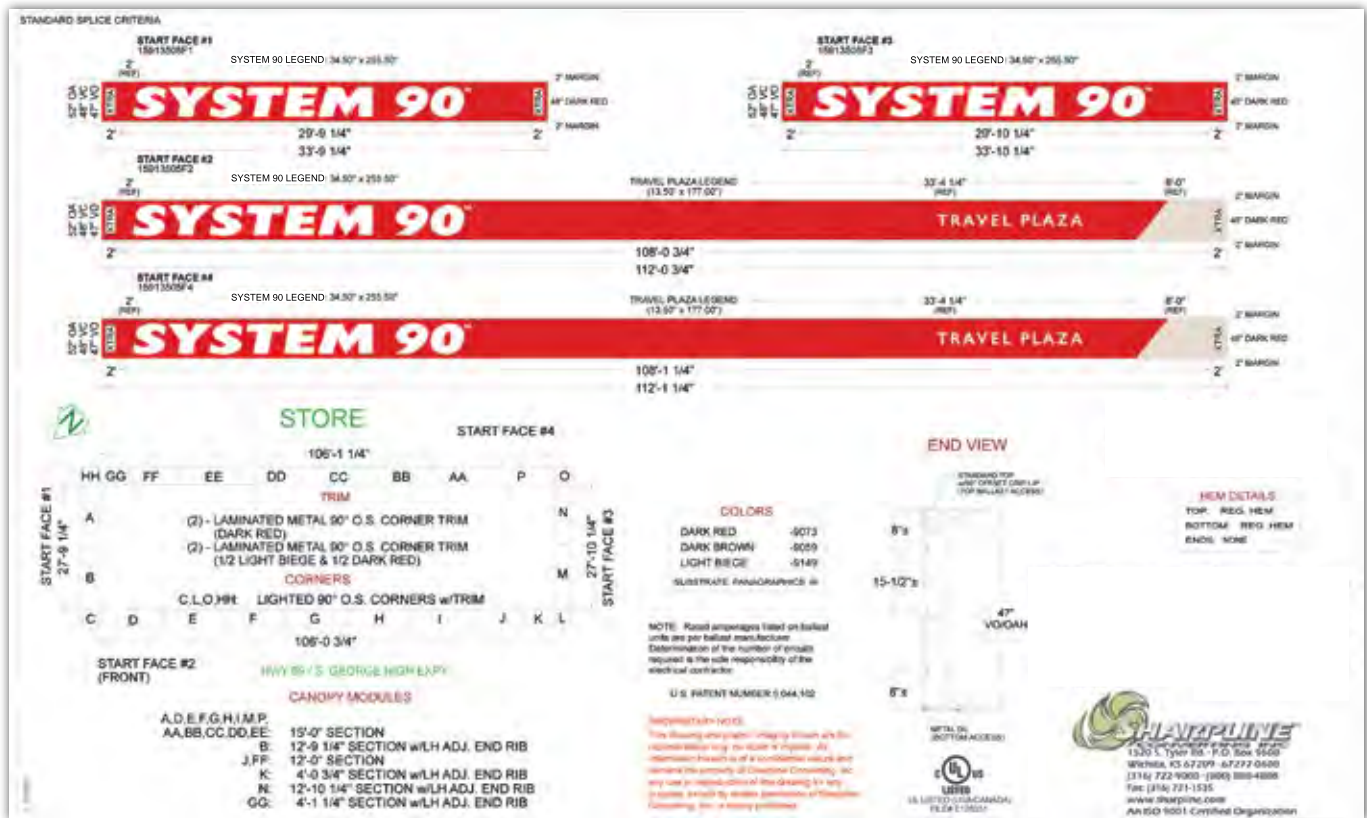

NOTE: Always verify the exact measurement of the facility against the dimensions on the plot plan.

Contact Sharpline immediately if the dimensions do not correspond.

STEP 1

Begin by establishing a horizontal reference line on the building or canopy for alignment of the sign cabinets. This can be done by snapping a chalk line on the structure.

Every installation is different, so the structure may have a unique reference point the sign cabinets need to line-up with. Many canopies use aluminum hat channels to hold cabinets in place.



STEP 2

Locate cabinet "A" on the plan view of the installation plot plan (supplied in the Information Package). Start the installation with cabinet "A".

Secure the cabinet to the structure by using "Z" clips on both the back top and bottom square tubing members in conjunction with fasteners (not supplied).



STEP 3

Two "Z" clips are required per vertical rib section. Butt a "Z" clip up to the back top 1" square tubing next to the vertical rib structure.

Use a 1/2" x #8 Hex Washer Head self-drilling screw in the pre-drilled hole of the clip to secure it to the cabinet. Then drill a pilot hole through the back skin of the cabinet and into the structure.

Use a grade 5 fastener to secure the clip to the structure.

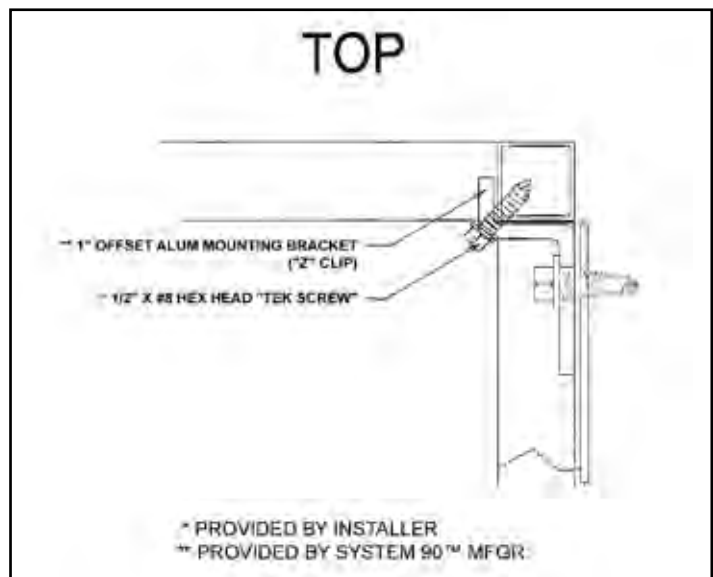

STEP 4

Install a "Z" clip butted down on the bottom 1" square tubing next to a vertical rib structure.

Follow the same procedure as listed in Step 3. This will secure the cabinet in place while the remaining clips are installed at each vertical rib structure.



STEP 5

After the initial "Z" clips are installed, use recommended fasteners (not supplied) to install the balance of the "Z" clips.

Repeat these steps for all remaining cabinets to be installed.



STEP 6

After the first cabinet is installed, position the next cabinet adjacent to the first cabinet, using the alignment tabs (located on the top and bottom extrusion) to guide the cabinets together.

The cabinets are bolted together with 4 - 5/16" x 2 1/2" bolts. Use a flat washer (provided) on each side of the square tubing when fastening. Tighten the bolts securely and evenly. Over-tightening may cause the square tubing to collapse.

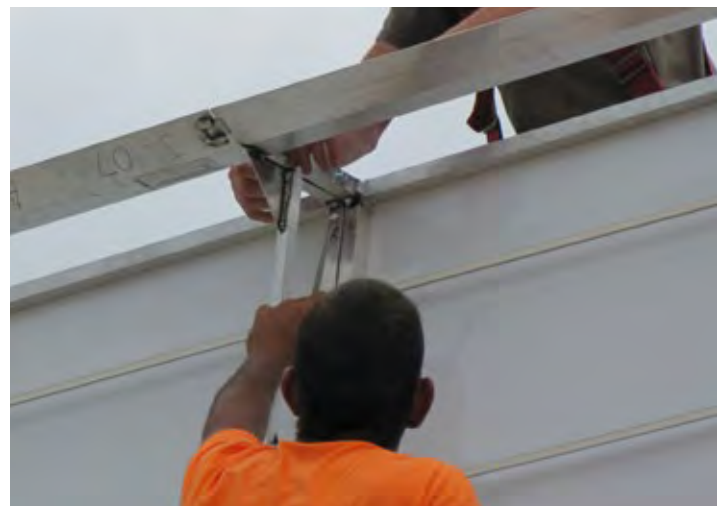

TYPES OF CABINET CORNERS

LIT 90° SQUARE CORNER

This type of corner is manufactured with a 3/8" thick clear acrylic vertical support.

This design allows a continuous run of flexible fascia to wrap around the corner. No trim is required and the corner is fully illuminated.



NON-LIT 90° SQUARE CORNER

This type of cabinet corner is manufactured with an aluminum vertical support for attachment of the flexible fascia. This design allows the start and stop of the flexible fascia at the corner.

A color-coordinated trim piece is provided to cap the attachment of the flexible fascia.



All cabinet corners are pre-drilled and bolted to a cabinet with 4 - 5/16" x 2 1/2" bolts and a flat washer (provided) on each side of the square tubing structure. When attaching an adjacent cabinet, use the alignment tabs to guide the corner and the cabinet together. Tighten the bolts securely and evenly. Over-tightening will cause the square tubing structure to collapse.

NOTE: Use a file as needed at all cabinet joints on the outer-most edge of the aluminum extrusion to insure a flush fit. This is also done to remove any sharp edges or welding burrs that may exist; causing puckers and/or damage in the flexible face installation.

TYPES OF CABINET CORNERS

OUTSIDE 90° RADIUS CORNER

This type of corner is manufactured using a custom-formed extrusion. There is no vertical support for the flexible fascia required.

This design allows a continuous run of flexible fascia to wrap around the corner. No trim is required, and the corner is fully illuminated.



INSIDE 90° CORNER

This type of cabinet corner is manufactured with aluminum vertical supports for attachment of the flexible fascia. This design allows the start and stop of the flexible fascia at the corner.

This design is used on all inside corner applications. A color-coordinated trim piece is provided to cap the attachment of the flexible fascia.



All cabinet corners are pre-drilled and bolted to a cabinet with 4 - 5/16" x 2 1/2" bolts and a flat washer (provided) on each side of the square tubing structure. When attaching an adjacent cabinet, use the alignment tabs to guide the corner and the cabinet together. Tighten the bolts securely and evenly. Over-tightening will cause the square tubing structure to collapse.

NOTE: Use a file as needed at all cabinet joints on the outer-most edge of the aluminum extrusion to insure a flush fit. This is also done to remove any sharp edges or welding burrs that may exist; causing puckers and/or damage in the flexible face installation.

COLD WEATHER ADVISORY

MINIMUM
45°
INSTALL
TEMP

The following advisory is based on the recommendations of the manufacturers of flexible fascia materials and related products:

When outdoor temperatures are below 45° F, avoid installations (i.e. attaching the finished sign faces to cabinets, framing, etc.) where folding, crimping, creasing or forming the material to sharp corners is necessary. At low temperatures, the material becomes less flexible and cracking may occur.

COLD WEATHER HINTS & TIPS

- Store flexible fascia in a warm, dry place until you are ready to do the installation.
- When inserting the 1/4" rods into the hem of the flexible fascia, have the fascia pulled straight and kink-free to prevent damage.
- Use very small amounts of WD-40 to help the rod slide through the hem easier. Be cautious of staining the flexible fascia.
- Work out all puckers in the flexible fascia by clamping a pair of duck bill vise grips (not provided) to the hem and rod. Then, use a hammer to gently tap the side of the vise grips in the direction needed to remove the pucker.
- A jet heater can be used to warm the section of flexible fascia being installed. CAUTION: Keep the heater at a safe distance and check the temperature of the fascia often to prevent damage.

Should you choose to install a flexible fascia in temperatures below 45° F, Sharpline will not be held responsible for any damage that may occur.

Replacement or repair of the flexible fascia will be the sole responsibility of the customer.

CARRIER ASSEMBLY

The System 90™ Flexible Backlit Fascia is installed on site using tools provided by Sharpline Converting Inc.

(Reference Tool List on page 5)



STEP 1

Remove the carrier components from the shipping container and place on a clean surface.

The roll of flexible fascia is clearly marked showing the top edge. Place the aluminum rod through the plastic caps in the core of the flexible fascia roll as shown.



STEP 2

Slide the metal support disk on to the bottom side of the flexible fascia roll...

Now slide the bottom platform member of the carrier onto the one inch diameter aluminum rod.



CARRIER ASSEMBLY

STEP 3

Slide the collar onto the aluminum rod to secure the bottom platform member.

Use a 3/32" Allen wrench to tighten the collar onto the aluminum rod.



STEP 4

Place the bottom triangular member onto the aluminum rod, flush with the top plastic cap in the core of the flexible fascia roll.



STEP 5

Slide the collar onto the aluminum rod so that it rests directly above the top triangular member.

Use a 3/32" Allen wrench to tighten the collar onto the aluminum rod. The carrier assembly is now complete.

NOTE: *The carrier is designed to accommodate different heights of flexible face rolls by loosening and repositioning the collars on each end of the carrier's aluminum rod.*



INSTALLING FASCIA

STEP 1

Start out with the flexible fascia even and level with the same amount of overlap on top and bottom. The top and bottom of the flexible fascia must be stretched at the same time. While the flexible fascia is being spring tensioned, make sure that the top and/or bottom does not get ahead of or behind the other by more than one foot.

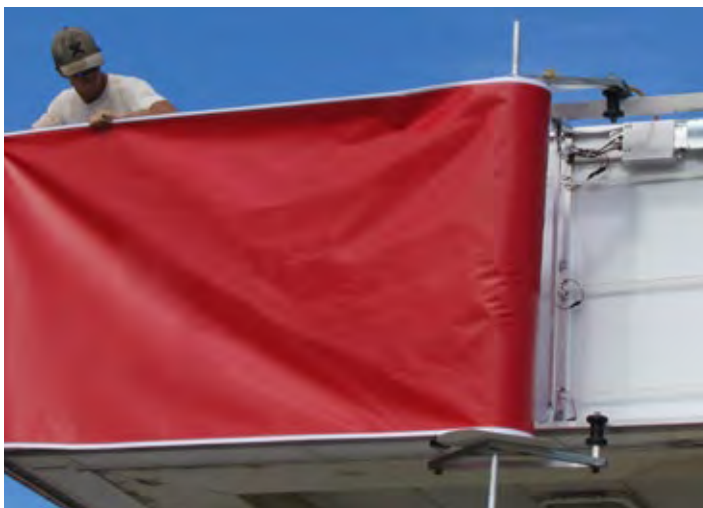

STEP 2

Referencing the plot plan, always work from left to right when installing the flexible fascia. The installer is responsible for checking proper placement of logos and legends according to the dimensions referenced on the plot plan.

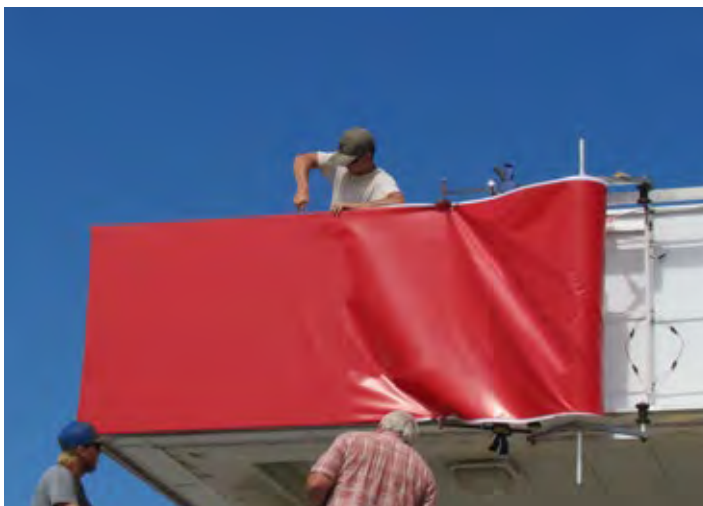

STEP 3

Hang the carrier with the flexible fascia on the installed cabinets. The top carrier member rollers will rest in the top extrusion of the cabinets. The bottom rollers will rest against the bottom extrusion of the cabinets.

Position the carrier approximately 10 feet to the right of the starting point. Secure a safety rope to the carrier as a safety precaution.



INSTALLING FASCIA

STEP 4

Unroll the flexible fascia and align the “Start of Fascia” marker at the left hand corner. Using clamps with protective ends, clamp the flexible face to the top extrusion.



STEP 5

ROD INSTALLATION INSTRUCTIONS FOR FLEXIBLE FASCIA

Cut a 1/4" slit through the sewn hem of the flexible fascia. It is important that you do not cut through the sewn hem or welded seam.



STEP 6

Insert one 1/4" x 6' plated steel rod into the hem at the top, and insert one 1/4" x 6' plated steel rod into the hem at the bottom.

NOTE: The rod should be cut 2 inches short of a corner. This will allow room for the flexible fascia and springs to fold over and not double up at the corner.



INSTALLING FASCIA

STEP 7A

INSTALLATION INSTRUCTIONS FOR FLEXIBLE FASCIA SPRINGS

Hook a spring over the rail inside the aluminum extrusion with the loop end of the spring out towards the flexible fascia.



STEP 7B

Next, hook the loop end of the spring around the shaft of the awl and place the point of the awl through the flexible fascia hem that the 1/4" rod has been inserted.

This creates a hole for the spring to penetrate through the flexible fascia and around the rod.



STEP 7C

Lever the awl toward the flexible fascia, thus stretching the spring and allowing it to slide down the shaft of the awl. Work the spring hook through the hole in the flexible fascia until it pops into place around the steel rod.



INSTALLING FASCIA

STEP 7D

The spring spacing is critical to provide an even distribution of tension on the flexible fascia:

12" to 36" tall sign cabinet

Spring spacing - 9" apart

40" to 60" tall sign cabinet

Spring spacing - 8" apart

At the insertion of a new rod, place a spring within two inches on both sides of the break.

STEP 8

Spring tension six feet of the flexible fascia on the top and bottom extrusion. This will give the horizontal stretchers enough tension to pull against.



STEP 9

Small puckers can be worked out by clamping the provided horizontal stretchers to the flexible fascia hem with the inserted rod. Gently tap the horizontal stretchers with a hammer until the pucker disappears.

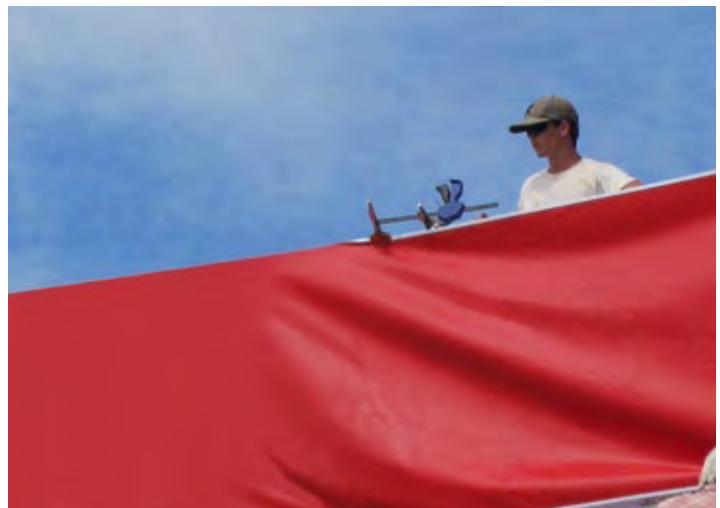

REPEAT THESE STEPS TO COMPLETE INSTALLATION

STEP 1

Make another 1/4" slit in the hem of the flexible fascia where the previous rod ends. It is important that you do not cut through the sewn hem or welded seam. Insert the next 1/4" x 6' plated steel rod into the top and bottom hem of the flexible fascia.

After this is complete, move down the cabinets a maximum of 15 feet and install the horizontal stretchers.



STEP 2

Clamp the back vice grip, the one closest to the handle to the extrusion. Then clamp the front vice grip to the hem on the flexible fascia.

By squeezing the handle of the top and bottom stretchers equally, you will apply the proper horizontal tension needed.

Do not tighten more than can be achieved by hand.



STEP 3

Once horizontal tension has been applied by the stretchers, the flexible fascia is ready for spring tensioning (page 18). Continue moving the carrier, the clamps and the stretchers down the extrusion of the cabinet. Do not allow the carrier to get more than 15 feet away from the work area.

Before going around the corner, install all of the springs on the top and bottom extrusion of the building's or canopy's first elevations.



STEP 1

The carrier will need removed at each corner and placed on the next elevation. Continue installing the rods and springs, making sure the rods do not overlap at the corners.



STEP 2

Use a pair of bolt cutters to cut the 1/4" plated steel rod to length before going around the corner. Cut the 1/4" plated steel rod approximately 2" short of the corner to allow the hem of the flexible fascia and springs enough room to recess properly in the aluminum extrusion.



STEP 3 BACKLIT TO ACM CORNER

See diagram as shown. Secure end cap to cabinet. Fold pre-routed ACM panel and place in position. Aligning top and bottom edges of cabinet and ACM panel, attach folded flapped area of ACM to vertical corner extrusion of cabinet with TEK screws. Apply final corner trim if necessary.

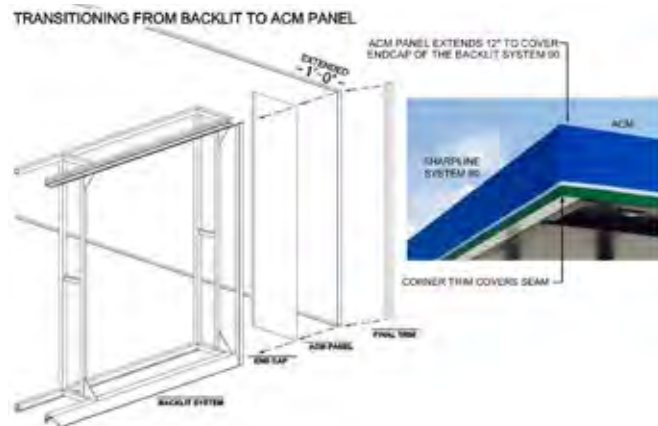

STEP 3A SQUARE SEAMLESS OUTSIDE CORNER

Use caution with the first horizontal stretch after you have rounded the corner. The horizontal tension needed to keep the flexible fascia tight usually pulls the plexiglass support slightly to one side. Re-align the support using the palm of your hand to push it back into alignment from the outside, after the flexible fascia has been spring-tensioned.



STEP 3B *SQUARE SEAMED OUTSIDE CORNER*

Stretch the flexible fascia tight to the outside edge of the vertical aluminum support. Attach the flexible fascia with rivets or 3/4" x 10-16 TEK screws (provided) every 4" along the vertical support of the corner. **Trim the excess flexible fascia flush with the support once it is secured, and install the metal trim piece with the TEK screws to finish out the corner.**



STEP 3C *SQUARE SEAMED INSIDE CORNER*

Thread the flexible fascia through the gap between the two vertical supports. Use duck-bill vise grips to stretch the fascia tight. Attach the flexible fascia with rivets or 3/4" x 10-16 TEK screws (provided) every 4" along the vertical support of the corner. **Trim the excess flexible fascia flush with the support once it is secured, and install the metal trim piece with the TEK screws to finish out the corner.**

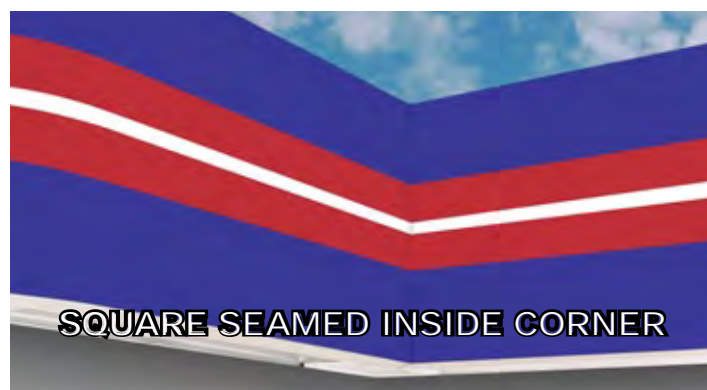

STEP 3D *ROUND SEAMLESS OUTSIDE CORNER*

Use caution when making the first horizontal stretch after you have rounded the corner. Excessive horizontal tension will almost always cause the flexible fascia to cup into the corner.

Be sure the 1/4" rod and springs are behind the triangle extrusion to allow proper fit of the top and bottom covers.



STEP 4

Once the flexible fascia is installed, secure the ends. Stretch and attach the flexible fascia to the exposed 3/4" x 3/4" vertical aluminum frame rib using 3/4" x 10-16 TEK screws, spaced 6" apart.

Once the flexible fascia is secure and wrinkle-free, cut away all the excess flexible fascia to allow the endcap to fit tight and flush with the front edge.



INSTALLING TRIM, TOPS, & SPRING COVERS

METAL CORNER TRIM INSTALLATION

Install the corner trim at this time. Be sure the trim fits tight and flush along the front vertical edge. This is necessary to prevent light leaks and achieve a finished appearance.

Use trim screws at the top and bottom of the corner trim to secure it to the vertical edge. Place cover-up dots on the tops of the trim screws to match the color of the vinyl trim.



METAL TOP INSTALLATION

The metal tops now need to be installed.

It is necessary to remove the white paper liner from the gasket material on the metal tabs between each section. All top seams need to be caulked to ensure a correct seal.

NOTE: When installing the tops, use 3/4" x 10-16 TEK screws on 12" centers (front and back), and 3 at the joint on each top panel.

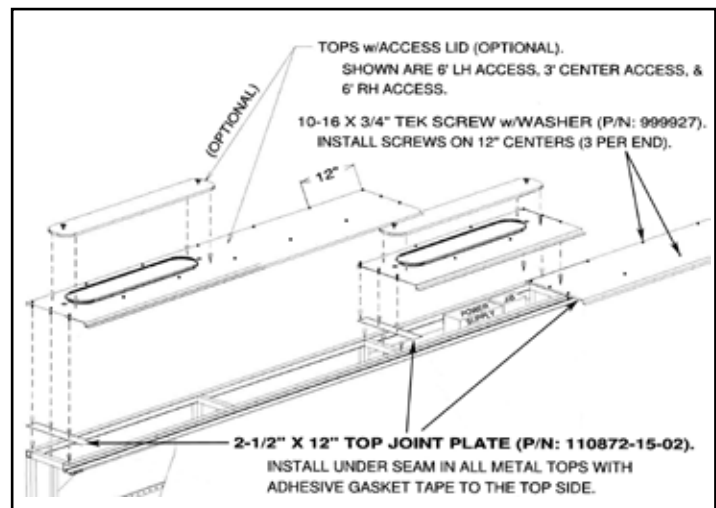

SPRING COVER INSTALLATION

Install the spring cover trim on the bottom of the flexible backlit fascia cabinets, using 1/2" x 10-24 flathead Phillips white screws (provided) at each pre-drilled hole.

CAUTION: Be sure the spring cover is flush with the front edge of the sign cabinet along the entire length before installing any screws. If the spring cover is started crooked, any attempt to push it back straight will cause the trim to buckle between screws.

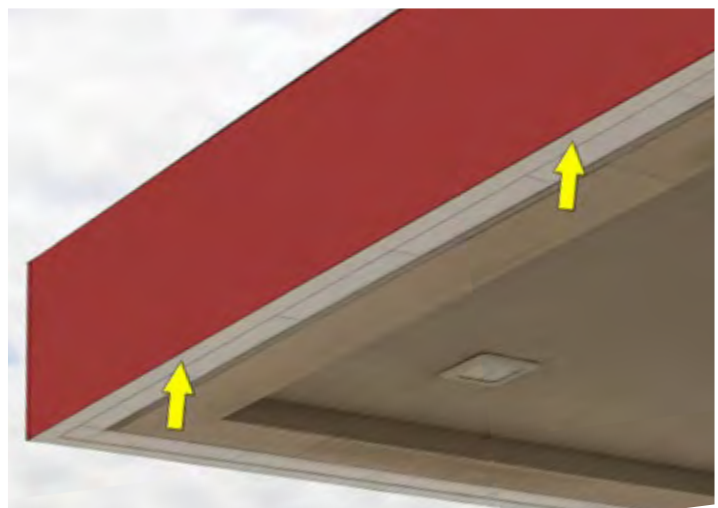

TRIMMING FINAL EGGCRATE PANEL TO LENGTH

EGGCRATE PANEL SIZE-TO-FIT KIT INSTRUCTIONS

STEP 1: MEASURE AND RECORD REQUIRED LENGTH

STEP 2: USE DIAGONAL CUTTERS, TIN SNIPS, OR SIMILAR CUTTERS TO TRIM PANEL TO FINAL REQUIRED LENGTH (CUTTING EACH INDIVIDUAL PLASTIC RIB).

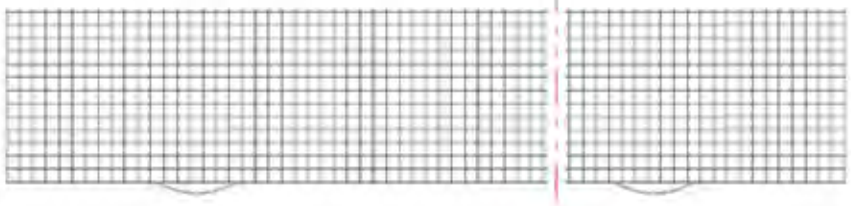
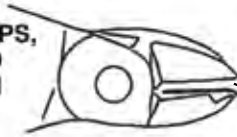

STEP 3: DRILL TWO HOLES APPROXIMATELY 3-1/8" APART USING PROVIDED 0.136" DRILL (#29) BIT ON 3/8" THICK FLAT SIDE OF PANEL.

.136" HOLE (#29 BIT)
4 PLACES TYP.



STEP 4: INSERT SPRING CLIP

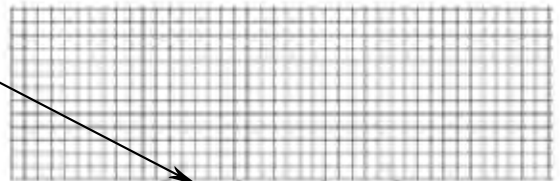

STEP 5: INSTALL ODD-SIZE EGGCRATE AND CHECK FIT. TRIM LENGTH MORE IF NEEDED.

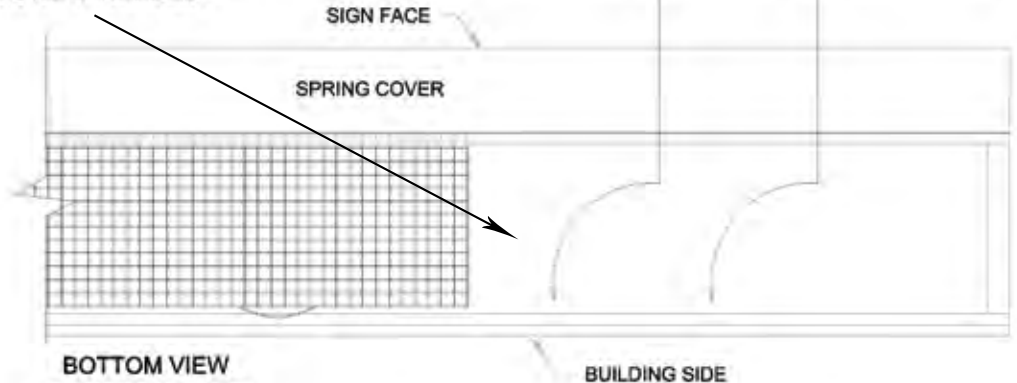

NOTE:

INSERT SPRING SIDE OF BOTTOM PANEL INTO BUILDING SIDE OF SLOT FIRST.
THEN PUSH INTO SLOT TO COMPRESS SPRINGS AND SLIDE OTHER SIDE INTO SLOT.

CLEANING INSTRUCTIONS FOR FLEXIBLE BACKLIT FASCIA:

Flexible fascia must be cleaned on a regular basis to maintain the bright vivid colors and crisp appearance. Cleaning the flexible fascia is a simple process, and will keep it looking like new for years by following the steps below:

STEP 1

ABIDE BY HEALTH AND SAFETY WARNINGS

When using any pre-mixed cleaning solutions, refer to the container's labeling for health, safety, and handling information.

STEP 2

PREPARE 1 OF 2 SOLUTIONS TO CLEAN THE FLEXIBLE FASCIA

Solution #1 consists of warm water mixed with a small amount of mild washing detergent. Use a soft sponge or cotton cloth to clean the surface of the flexible fascia.

Do not excessively wipe or rub the front decorated surface when cleaning. Rinse thoroughly with water to remove any soap residue.

Solution #2 consists of two parts of water mixed with one part of isopropyl alcohol. Utilizing a spray bottle, mist the surface of the flexible fascia and wipe clean with a damp cloth.

STEP 3

PRACTICE FREQUENT CLEANING FOR BEST RESULTS

Institute a routine cleaning schedule into the operational maintenance of each system.

DO NOT USE ANY OF THE FOLLOWING TO CLEAN THE FLEXIBLE FASCIA:

- Denatured Alcohol
- Lacquer Thinner
- Gasoline
- Bleach
- Organic Solvents

Replacement of Fluorescent Lamps (if so equipped)
Use **ONLY T-12/DHO (800MA)** fluorescent daylight lamps.

Sharpline Converting Inc. warrants the electrical components of System 90™ to be free from defects in material and factory workmanship for a period of one year from the date of purchase. The labor warranty extends for a period of 90 days from the date of purchase.

PARTS COVERAGE

Under this warranty, Sharpline Converting Inc.'s obligation covers the replacement, repair, and/or correction of electrical components of System 90™. This warranty applies to purchases made within the stated duration along with verification of defects by Sharpline or authorized personnel.

Sharpline reserves the right to supply only the parts, materials, and/or components necessary for replacement, repair, or correction. Maintenance items (i.e. LED lights) are not covered under this warranty.

Sharpline is not liable for any loss, consequential damage, and/or repair expense that incurs directly or indirectly from the use of equipment at time of installation and/or warranty work.

The terms and conditions of this warranty apply only to unmodified System 90™ units. Any modifications made to a System 90™ unit without written authorization from Sharpline invalidates this warranty.

LABOR CLAIMS

Under this warranty, to receive authorization for replacement, repair, and/or correction of electrical components during the warranty period, prior notice to Sharpline of the warranty claim is required. Without prior notice, the warranty claim will be denied. For claim authorization, inspection by a Sharpline Representative or authorized personnel may be required.

Upon authorization from a Sharpline Representative for replacement, repair, and/or correction, this warranty holds a maximum labor rate of \$55/hour with a 3 hour maximum per warranty claim. Labor charges and time consumption that exceed these limits will be denied.

Any additional warranties, expressed or implied, are null and void. In addition, Sharpline Converting Inc. bears no responsibility for liability of injuries to person or damage resulting from alteration, modification, or negligent maintenance of equipment and/or safety devices used by purchaser or contracted labor.

For questions and/or processing warranty claims, please call Sharpline at 1-800-888-4888 and ask for an Architectural Graphics Projects Coordinator to assist your needs.

System 90™, Sharpine's Flexible Backlit Fascia and Sign System, is a trademark of Sharpline Converting Inc.

This Site Information Summary must be completed with photos submitted to Sharpline prior to approval of any installation invoices. Scan a copy of this completed form, save as a PDF, and submit with JPEG photos (phone pics are acceptable) to **siteinfo@sharpline.com**.

Location

Installation Company: _____

Crew: _____

Completion Date: _____

YES NO COMMENTS

Cabinets fastened securely in place according to the provided Installation Manual?

____ _

Fascia system wired to the primary source according to NEC Code and tested for proper illumination?

____ _

Fascia clean and wrinkle-free?

____ _

Tops installed and sealed properly?

____ _

Bottom spring cover trim installed properly?

____ _

Down light / access panels clean and in place?

____ _

Corner vertical acrylic supports straight?

____ _

Punch-list of remaining items to be completed?

____ _

Any suggestions or comments?

____ _

The above job has been completed in accordance with the specifications called out in the System 90™ Installation Manual.

Installation Crew Chief Signature

Date